

ENGLAND FAMILY RACING



Sponsor Proposal



Having overcome Hodgkins Lymphoma, Benjamin is eager to give his all to his racing career and to our team. He is a fighter, filled with determination, passion, positivity and perseverance. His videos on our social media are always received very well as Benjamin speaks with an amazing depth of passion and knowledge for both the causes we represent and our partners. With your help, we can reach a wider community and thus advertise your brand as part of your partnership. We use social media to update our fans and community throughout race meets, the platforms we use are both Facebook and Instagram.

To whom this may concern,

We are Longland Family Racing, a Queensland based Superkart team. Our team is comprised of our Driver and Team Principle., Benjamin Longland and our Manager, Jessica Burke. We are family orientated and dedicated to our causes and our partnerships. We are currently aligned with Racing With Autism Australia as Benjamin has Autism himself and is one of the most recognised personalities in the organisation along with Lymphoma Australia as he is a survivor of stage 3 advanced, Hodgkins Lymphoma. Our team was initially started out of our garage in 2018. It has grown since then and we are aiming to spread awareness for our causes and our partnerships while competing in the sport that we love.



Your company will be tagged in each post and named as a new partner coming onboard for the continuation of our racing year for 2022. We would also want to introduce you to our community and explain what you do and how important your partnership is to our race team.

We believe now is the right time to bring on a new partner for our team as the next 2 rounds that we are attending are being broadcast live on Youtube and telecast later on in the year on 7Mate. This has presented our team and sport with a unique opportunity having only been broadcast live at events such as Sydney's Muscle Car Masters at Sydney Motorsport Park. We are aiming to use these opportunities to create awareness for Lymphoma Australia leading into and during Lymphoma Awareness Month which falls in September. It is due to this that we believe that this would achieve a maximum

level of exposure for your brand during this time. We also are reaching out to media outlets in the build up to these events which again is an ideal opportunity for further brand exposure.

“Having overcome Hodgkins Lymphoma, Benjamin is eager to give his all to his racing career”

We are writing to you today to invite you to join our team for the remainder of the 2022 racing season. This September is Lymphoma Awareness Month and as part of this, we are aiming to gain a sponsorship. We are asking for an investment of \$2500 which will go towards wrapping our Superkart in lime green so that we stand out on the track to gain much needed attention for Lymphoma Australia. Included in this, is a prime position for your business on the nose cone and side pods of our kart. We are eager to raise awareness, to be a voice for the voiceless and to also push our motorsport forward. Australian Motorsport is a huge industry, from the grassroots racing to the top tier of racing. There is something for everyone at any age and ability.

We will ensure that your sponsorship and partnership are well exposed to our wider community as mentioned above, thus gaining exposure for your company and your brand alongside



amazing charities and not for profits. We believe that partnering with us for the final months of 2022 will lead to a solid foundation and prosperous relationship moving forward.



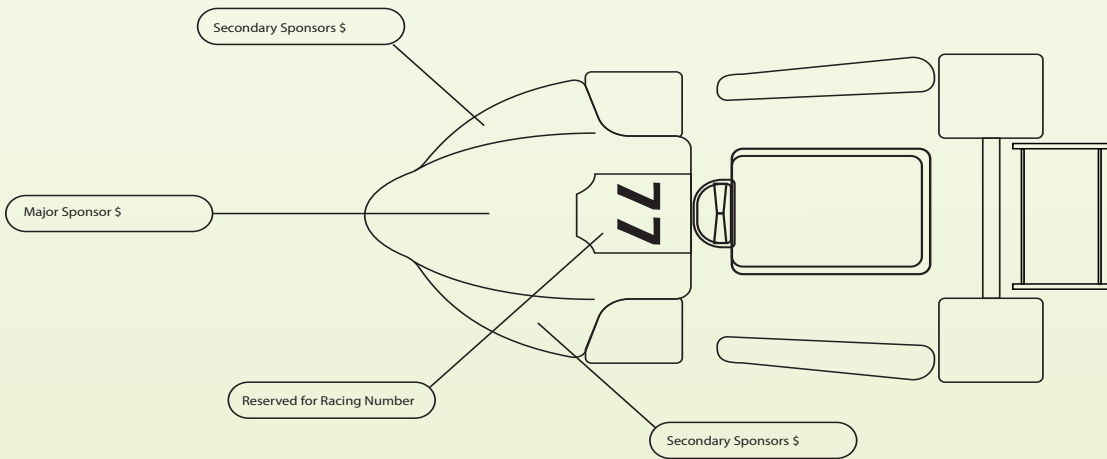
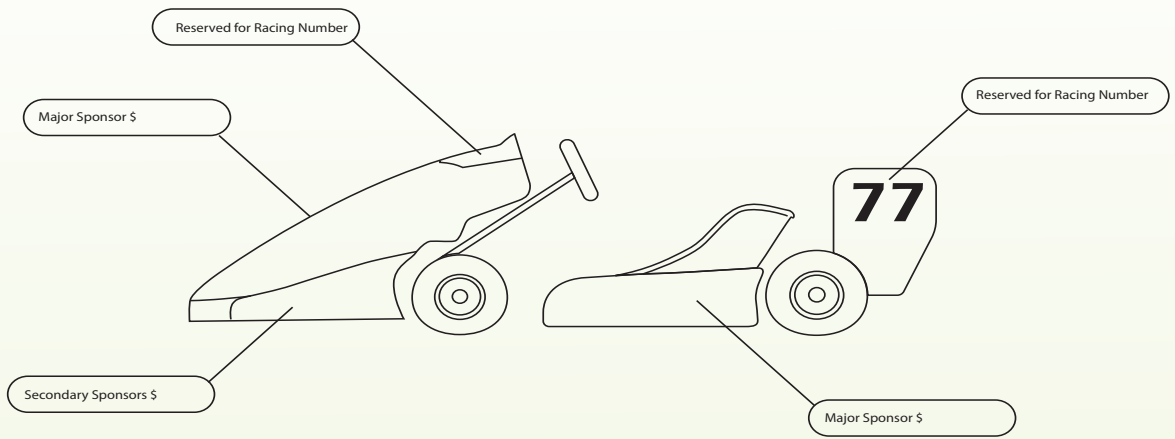

Thank you for taking the time to review our proposal and we look forward to hearing from you.

Regards

Longland Family Racing



0402 081 713



longlandfamilyracing@outlook.com



@longlandfamilyracing



Longland Family Racing

